

# Test Report

Applicant: Guangzhou Xuntian Electronic Technology Co., Ltd

Product Name: Sealed Lead Acid Battery

Brand Name: JRH

Model No.: 12V120AH, 12V18AH, 12V24AH, 12V33AH, 12V38AH,  
12V42AH, 12V50AH, 12V55AH, 12V65AH, 12V70AH,  
12V80AH, 12V90AH, 12V100AH, 12V150AH, 12V200AH,  
12V250AH

Date of Receipt: Dec.01,2022  
Date of Test: Dec.02,2022  
Date of Report: Dec.05,2022

Prepared by: Shenzhen Most Technology Service Co., Ltd.



**The EMC testing has been performed on the submitted samples and found in compliance with the council EMC directive 2014/30/EU.**

Shenzhen Most Technology Service Co., Ltd.  
No.5, 2nd Langshan Road, North District, Hi-tech Industry Park,  
Nanshan, Shenzhen, Guangdong, China  
Phone: 86-755-86026850  
Fax: 86-755-26013350  
[http:// www.szmost.com](http://www.szmost.com)

## TABLE OF CONTENTS

Description	Page
Test Report Declaration.....	4
<b>1. GENERAL INFORMATION .....</b>	<b>4</b>
1.1. Description of Device (EUT) .....	4
1.2. Operational Mode(s) of EUT.....	4
1.3. Test Voltage(s) of EUT .....	4
<b>2. DESCRIPTION OF TEST STANDARD .....</b>	<b>5</b>
<b>3. LABORATORY INFORMATION.....</b>	<b>6</b>
3.1. Laboratory Name .....	6
3.2. Location .....	6
3.3. Test facility .....	6
3.4. Measurement Uncertainty.....	6
<b>4. SUMMARY OF TEST RESULTS.....</b>	<b>7</b>
<b>5. BLOCK DIAGRAM OF TEST SETUP .....</b>	<b>8</b>
5.1. Block Diagram of connection between EUT and simulation-EMI .....	8
5.2. Block Diagram of connection between EUT and simulation-EMS.....	8
<b>6. TEST INSTRUMENT USED.....</b>	<b>9</b>
6.1. For Radiation Test (In Anechoic Chamber) .....	9
6.2. For Electrostatic Discharge Immunity Test.....	9
6.3. For RF Strength Susceptibility Test .....	9
6.4. For Magnetic Field Immunity Test.....	9
<b>7. RADIATED DISTURBANCE TEST .....</b>	<b>10</b>
7.1. Configuration of Test System.....	10
7.2. Test Standard .....	10
7.3. Radiated Disturbance Limit.....	10
7.4. Test Procedure .....	10
7.5. Radiated Disturbance Test Results.....	11
<b>8. IMMUNITY PERFORMANCE CRITERIA.....</b>	<b>12</b>
<b>9. ELECTROSTATIC DISCHARGE IMMUNITY TEST .....</b>	<b>13</b>
9.1. Configuration of Test System.....	13
9.2. Test Standard .....	13
9.3. Severity Levels and Performance Criterion.....	14
9.4. Test Procedure .....	14
9.5. Test Results .....	14
<b>10. RF FIELD STRENGTH SUSCEPTIBILITY TEST .....</b>	<b>16</b>
10.1. Configuration of Test System.....	16
10.2. Test Standard .....	16
10.3. Severity Levels and Performance Criterion.....	16
10.4. Test Procedure .....	17
10.5. Test Results .....	17
<b>11. MAGNETIC FIELD IMMUNITY TEST .....</b>	<b>20</b>
11.1. Configuration of Test System.....	20
11.2. Test Standard .....	20
11.3. Severity Levels and Performance Criterion.....	20
11.4. Test Procedure .....	21
11.5. Test Results .....	21
 APPENDIX I	 (4 pages)
APPENDIX II(Photos of the EUT )	(2 pages)

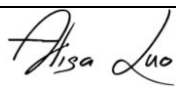
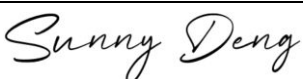
## TEST REPORT DECLARATION

Report Number	MTEB22111724	
Applicant	Guangzhou Xuntian Electronic Technology Co., Ltd	
	9/F, No. 4, Kehui 1st Street, Huangpu District, Guangzhou	
Manufacturer	Guangdong Xuntian New Energy Co., Ltd	
	Non-ferrous Metal Recycling Economic Industrial Base Management Committee, Zhoutian Town, Renhe County, Shaoguan City, Guangdong, China	
Product	Product Name	Sealed Lead Acid Battery
	Model No.	12V120AH
	Power Supply	DC 12V by Battery DC 15V by DC Source
Test Result	The EUT was found compliant with the requirement(s) of the standards.	
Standard	EN IEC 61000-6-3:2021, EN IEC 61000-6-1:2019	
<p><b>*Note</b></p> <p>The above device has been tested by Shenzhen Most Technology Service Co., Ltd. To determine the maximum emission levels emanating from the device and the severe levels of the device can endure and its performance criterion. The test record, data evaluation &amp; Equipment Under Test (EUT) configurations represented are contained in this test report and Shenzhen Most Technology Service Co., Ltd. Is assumed full responsibility for the accuracy and completeness of test. Also, this report shows that the EUT is technically compliant with the requirement of the above standards.</p> <p>This report applies to above tested sample only. This report shall not be reproduced except in full, without written approval of Shenzhen Most Technology Service Co., Ltd., this document may be altered or revised by Shenzhen Most Technology Service Co., Ltd., personal only, and shall be noted in the revision of the document.</p>		
Prepared by		
	Alisa Luo(Engineer)	
Reviewed by		
	Sunny deng(Engineer)	
Approved by		
	Yvette Zhou(Manager)	

# 1. GENERAL INFORMATION

## 1.1. Description of Device (EUT)

Description	:	Sealed Lead Acid Battery
Model Number	:	12V120AH, 12V18AH, 12V24AH, 12V33AH, 12V38AH, 12V42AH, 12V50AH, 12V55AH, 12V65AH, 12V70AH, 12V80AH, 12V90AH, 12V100AH, 12V150AH, 12V200AH, 12V250AH
Remark	:	Used 12V120AH does all tests

## 1.2. Operational Mode(s) of EUT

Order Number	:	Test Mode(s)
1	:	Discharging
2	:	Charging

## 1.3. Test Voltage(s) of EUT

Order Number	:	Test Voltage(s)
1	:	DC 12V by Battery
2	:	DC 15V by DC Source

## 2. DESCRIPTION OF TEST STANDARD

The intention of this publication is to establish uniform requirements for the radio disturbance level of the equipment contained in the scope, to fix limits of disturbance, to describe methods of measurement and to standardize operating conditions and interpretation of results.

The following referenced standard are indispensable for the application of this report.

Referenced Description below:

EN IEC 61000-6-3:2021

Electromagnetic compatibility (EMC) -- Part 6-3: Generic standards - Emission standard for residential, commercial and light-industrial environments.

EN IEC 61000-6-1:2019

Electromagnetic compatibility (EMC) -- Part 6-1: Generic standards - Immunity for residential, commercial and light-industrial environments.

### 3. LABORATORY INFORMATION

#### 3.1. Laboratory Name

Shenzhen Most Technology Service Co., Ltd.

#### 3.2. Location

No.5, 2nd Langshan Road, North District, Hi-tech Industrial Park, Nanshan, Shenzhen, Guangdong, China

#### 3.3. Test facility

- 3m Anechoic Chamber : Nov. 28, 2012 File on Federal Communication Commission  
Registration Number:490827
  
- Shielding Room : Nov. 28, 2012 File on Federal Communication Commission  
Registration Number:490827
  
- EMC Lab. : Accredited by TUV Rheinland Shenzhen  
Audit Report: UA 50149851  
Mar. 12, 2009  
  
 Accredited by Industry Canada  
 Registration Number: 7103A-1  
 Oct. 22, 2012  
  
 Accredited by TIMCO  
 Registration Number: Q1460  
 March 28, 2010

#### 3.4. Measurement Uncertainty

No.	Item	Uncertainty
1.	Uncertainty for Conducted Disturbance Test	1.25dB
2.	Uncertainty for Radiated Disturbance Test	3.15dB

#### 4. SUMMARY OF TEST RESULTS

<b>EMISSION</b>			
<b>Test Item</b>	<b>Standard</b>	<b>Limits</b>	<b>Results</b>
Conducted disturbance at mains terminals	EN IEC 61000-6-3:2021	---	N/A
Radiated disturbance	EN IEC 61000-6-3:2021	---	PASS
Harmonic current emissions	EN IEC 61000-3-2:2019+A1:2021	---	N/A
Voltage fluctuations & flicker	EN 61000-3-3:2013+A1:2019 +A2:2021	---	N/A
<b>IMMUNITY (EN IEC 61000-6-1:2019)</b>			
<b>Test Item</b>	<b>Basic Standard</b>	<b>Performance Criteria</b>	<b>Results</b>
Electrostatic discharge (ESD)	EN 61000-4-2:2009	B	PASS
Radio-frequency, Continuous radiated disturbance	EN IEC 61000-4-3:2020	A	PASS
Electrical fast transient (EFT)	EN 61000-4-4:2012	---	N/A
Surge (Input a.c. power ports)	EN 61000-4-5:2014+A1:2017	---	N/A
Surge (Telecommunication ports)		---	N/A
Radio-frequency, Continuous conducted disturbance	EN 61000-4-6:2014	---	N/A
Power frequency magnetic field	EN 61000-4-8:2010	A	PASS
Voltage dips, 0% reduction	EN IEC 61000-4-11:2020	---	N/A
Voltage dips, 30% reduction		---	N/A
Voltage interruptions		---	N/A
N/A is an abbreviation for Not Applicable.			

## 5. BLOCK DIAGRAM OF TEST SETUP

The equipments are installed test to meet EN61000-6-3 requirement and operating in a manner which tends to maximize its emission characteristics in a normal application. EUT was tested in normal configuration (Please See following Block diagrams)

### 5.1. Block Diagram of connection between EUT and simulation-EMI

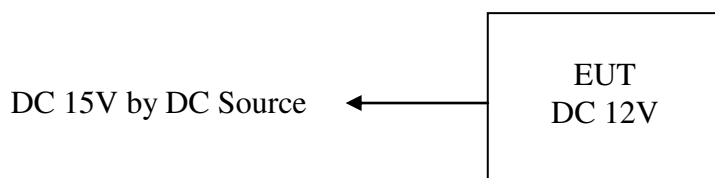

(EUT: Sealed Lead Acid Battery )

### 5.2. Block Diagram of connection between EUT and simulation-EMS

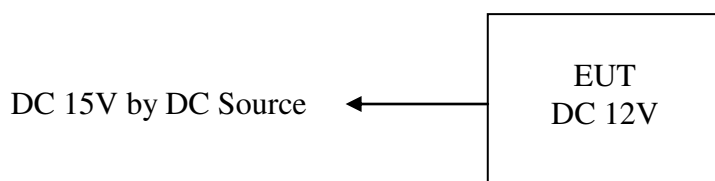

(EUT: Sealed Lead Acid Battery )

## 6. TEST INSTRUMENT USED

### 6.1. For Radiation Test (In Anechoic Chamber)

Item	Equipment	Manufacturer	Model No.	Serial No.	Last Cal.	Cal. Interval
1.	Test Receiver	Rohde & Schwarz	ESPI	101202	Mar. 04, 22	1 Year
2.	Bilog Antenna	Sunol	JB3	A121206	Mar. 04, 22	1 Year
3.	Cable	Resenberger	N/A	NO.1	Mar. 04, 22	1 Year
4.	Cable	SchwarzBeck	N/A	NO.2	Mar. 04, 22	1 Year
5.	Cable	SchwarzBeck	N/A	NO.3	Mar. 04, 22	1 Year
6.	DC Power Filter	DuoJi	DL2×30B	N/A	N/A	N/A
7.	Single Phase Power Line Filter	DuoJi	FNF 202B30	N/A	N/A	N/A
8.	3 Phase Power Line Filter	DuoJi	FNF 402B30	N/A	N/A	N/A

### 6.2. For Electrostatic Discharge Immunity Test

Item	Equipment	Manufacturer	Model No.	Serial No.	Last Cal.	Cal. Interval
1.	ESD Tester	Zhongsheng	ESD-203AX	023K14538	Mar. 04, 22	1 Year

### 6.3. For RF Strength Susceptibility Test

Item	Equipment	Manufacturer	Model No.	Serial No.	Last Cal.	Cal. Interval
1.	Signal Generator	IFR	2032	203002/100	Mar. 04, 22	1 Year
2.	Amplifier	A&R	150W1000	301584	NCR	NCR
3.	Dual Directional Coupler	A&R	DC6080	301508	Mar. 04, 22	1 Year
4.	Power Sensor	Anritsu	MA2491A	32263	Mar. 04, 22	1 Year
5.	Power Meter	R&S	NRVS	100444	Mar. 04, 22	1 Year
6.	Field Monitor	A&R	FM5004	300329	Mar. 04, 22	1 Year
7.	Field Probe	A&R	FP5000	300221	Mar. 04, 22	1 Year
8.	Log-periodic Antenna	A&R	AT1080	16512	Mar. 04, 22	1 Year
9.	RF Cable	MIYAZAKI	N/A	No.1/No.2	Mar. 04, 22	1 Year

### 6.4. For Magnetic Field Immunity Test

Item	Equipment	Manufacturer	Model No.	Serial No.	Last Cal.	Cal. Interval
1.	EMC PRO System	EM Test	UCS-500-M4	V0648102026	Mar. 04, 22	1 Year

## 7. RADIATED DISTURBANCE TEST

### 7.1. Configuration of Test System

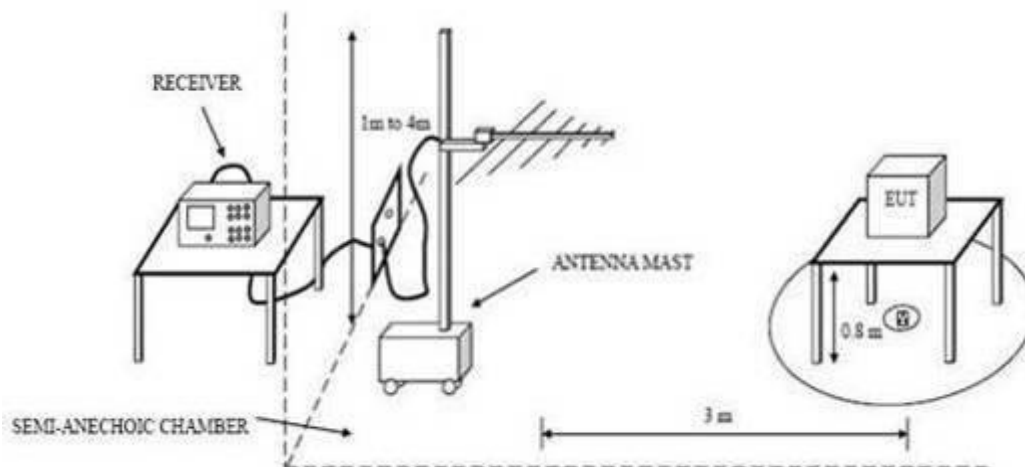

### 7.2. Test Standard

EN IEC 61000-6-3:2021

### 7.3. Radiated Disturbance Limit

All emanations from devices or system, including any network of conductors and apparatus connected thereto, shall not exceed the level of field strengths specified below:

FREQUENCY (MHz)	DISTANCE (Meters)	FIELD STRENGTHS LIMITS (dB $\mu$ V/m)
30 ~ 230	3	40
230 ~ 1000	3	47

Note: 1. The lower limit shall apply at the transition frequencies.

2. Distance refers to the distance in meters between the test antenna and the closed point of any part of the EUT.

### 7.4. Test Procedure

The EUT was placed on a non-metallic table, 80 cm above the ground plane inside a semi-anechoic chamber. An antenna was located 3m from the EUT on an adjustable mast. A pre-scan was first performed in order to find prominent radiated emissions. For final emissions measurements at each frequency of interest, the EUT were rotated and the antenna height was varied between 1m and 4m in order to maximize the emission. Measurements in both horizontal and vertical polarities were made and the data was recorded. In order to find the maximum emission, the relative positions of equipments and all of the interface cables were changed according to EN 61000-6-3 on Radiated Disturbance test.

The bandwidth setting on the test receiver is 120 kHz.

The frequency range from 30MHz to 1000MHz is checked. The test result are reported on Section 7.5.

## 7.5. Radiated Disturbance Test Results

7.5.1. Test Results: **PASS**

7.5.2. Emission Level = Correct Factor + Reading Level.

7.5.3. All readings are Quasi-Peak values.

7.5.4. The test data and the scanning waveform are attached within Appendix I.

## **8. IMMUNITY PERFORMANCE CRITERIA**

The test results shall be classified in terms of the loss of function or degradation of performance of the equipment under test, relative to a performance level by its manufacturer or the requestor of the test, or the agreed between the manufacturer and the purchaser of the product.

### **Criterion A:**

The apparatus shall continue to operate as intended during and after the test. No degradation of performance or loss of function is allowed below a performance level specified by the manufacture, when the apparatus is used as intended. The performance level may be replaced by a permissible loss of performance. If the minimum performance level of the permissible performance loss is not specified by the manufacturer, either of these may be derived from the product description and documentation and what the user may reasonably expect from the apparatus if used as intended.

### **Criterion B:**

The apparatus shall continue to operate as intended after the test. No degradation of performance or loss of function is allowed below a performance level specified by the manufacture, when the apparatus is used as intended. The performance level may be replaced by a permissible loss of performance. During the test, degradation of performance is however allowed. No change of actual operating state or stored data is allowed. If the minimum performance level of the permissible performance loss is not specified by the manufacturer, either of these may be derived from the product description and documentation and what the user may reasonably expect from the apparatus if used as intended.

### **Criterion C:**

Temporary loss of function is allowed, provided the function is self-recoverable or can be restored by the operation of the controls.

## 9. ELECTROSTATIC DISCHARGE IMMUNITY TEST

### 9.1. Configuration of Test System

#### 9.1.1. Configuration of ESD Test System(Direct Discharge)

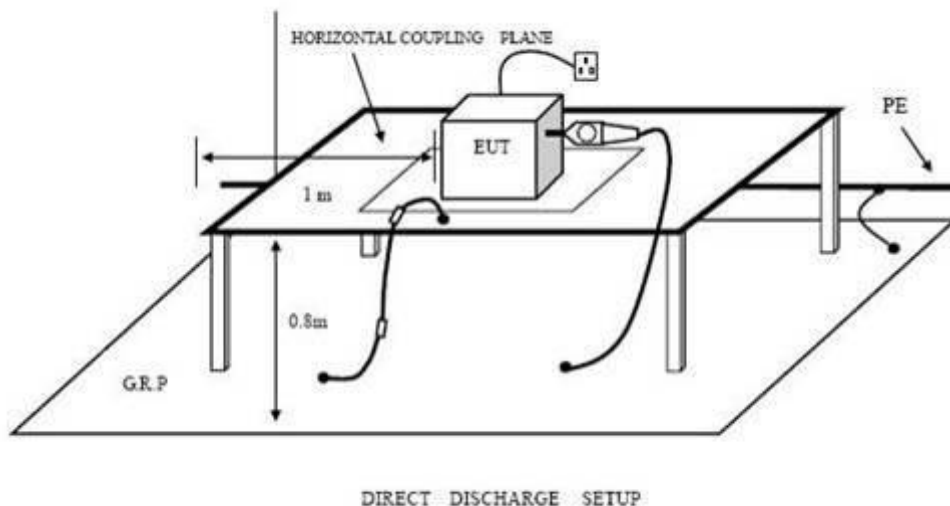

#### 9.1.2. Configuration of ESD Test System(Indirect Discharge)

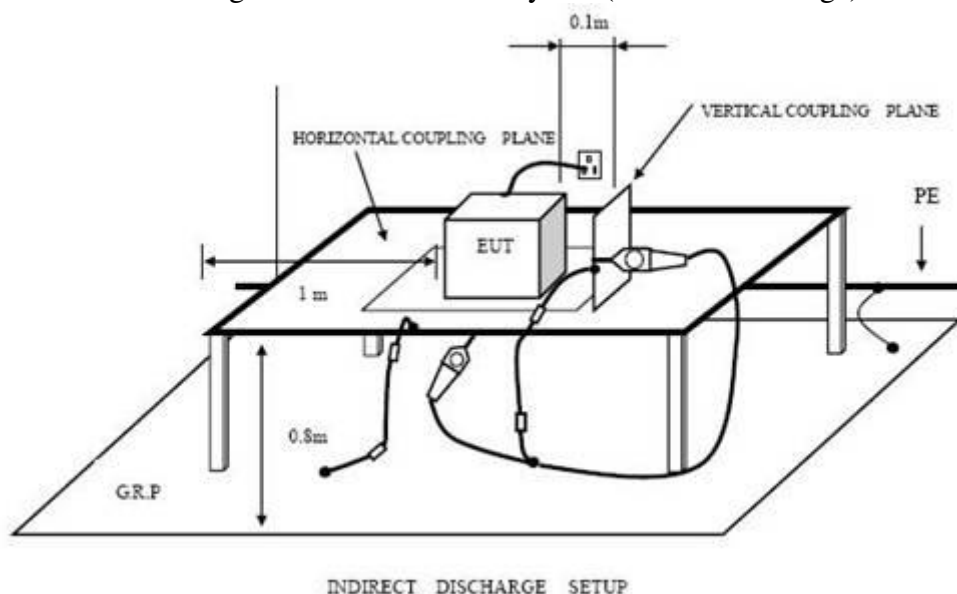

### 9.2. Test Standard

EN IEC 61000-6-1:2019 (EN 61000-4-2)  
 (Severity Level 3 for Air Discharge at 8KV,  
 Severity Level 2 for Contact Discharge at 4KV)

### 9.3. Severity Levels and Performance Criterion

#### 9.3.1. Severity level

Level	Test Voltage Contact Discharge (KV)	Test Voltage Air Discharge (KV)
1.	2	2
2.	4	4
3.	6	8
4.	8	15
X	Special	Special

#### 9.3.2. Performance criterion : **B**

### 9.4. Test Procedure

#### 9.4.1. Air Discharge:

The test was applied on non-conductive surfaces of EUT. The round discharge tip of the discharge electrode was approached as fast as possible to touch the EUT. After each discharge, the discharge electrode was removed from the EUT. The generator was re-triggered for a new single discharge and repeated 20 times for each pre-selected test point. This procedure was repeated until all the air discharge completed

#### 9.4.2. Contact Discharge:

All the procedure was same as Section 9.4.1. except that the generator was re-triggered for a new single discharge and repeated 20 times for each pre-selected test point. the tip of the discharge electrode was touch the EUT before the discharge switch was operated.

### 9.5. Test Results

#### 9.5.1. Test Results: **PASS**

#### 9.5.2. Test data on the following pages.

# Electrostatic Discharge Test Results

Shenzhen Most Technology Service Co., Ltd.

<i>Test Voltage</i> :	1&2	<i>Test Date:</i>	Dec.02,2022
<i>Test Mode</i> :	1&2	<i>Criterion</i> :	B
<i>Temperature:</i>	21.4 °C	<i>Humidity:</i>	51.0%
<i>Air Discharge: ±2,4 and 8KV</i>		<i># For Air Discharge each Point Positive 10 times and negative 10 times discharge.</i>	
<i>Contact Discharge: ±4KV</i>		<i># For Contact Discharge each point positive 10 times and negative 10 times discharge</i>	
<i>Test Results Description</i>			
<b><i>Location</i></b>	<b><i>Kind</i></b> A-Air Discharge C-Contact Discharge	<b><i>Result</i></b>	
<i>HCP</i>	C	PASS	
<i>VCP of Front</i>	C	PASS	
<i>VCP of Rear</i>	C	PASS	
<i>VCP of Left</i>	C	PASS	
<i>VCP of Right</i>	C	PASS	
<i>Remark :</i>			

*Discharge was considered on Contact and Air and Horizontal Coupling Plane (HCP) and Vertical Coupling Plane (VCP).*

Reviewer :                     Sunny

# 10. RF FIELD STRENGTH SUSCEPTIBILITY TEST

## 10.1. Configuration of Test System

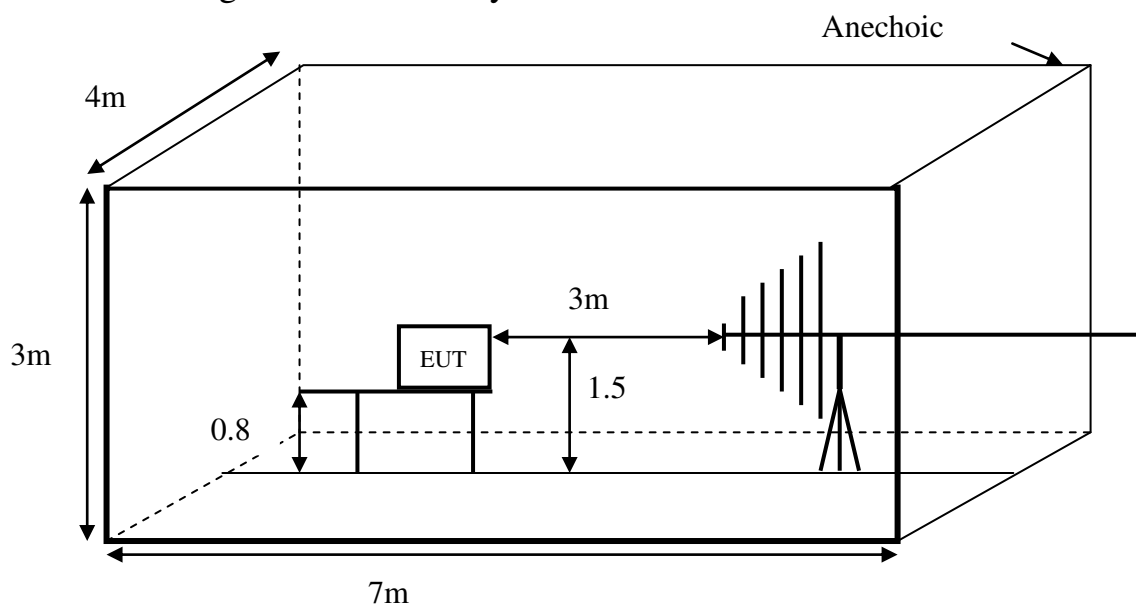

## 10.2. Test Standard

EN IEC 61000-6-1:2019 (EN IEC 61000-4-3)  
 (Severity Level: 2 at 3V / m)

## 10.3. Severity Levels and Performance Criterion

### 10.3.1. Severity level

Level	Test Field Strength V/m
1.	1
2.	3
3.	10
X	Special

### 10.3.2. Performance criterion : A

## 10.4. Test Procedure

Testing was performed in a Fully anechoic chamber as recommended by IEC 61000-4-3. The EUT was placed on an 80 cm high non-conductive table located in the area of field uniformity. The radiating antenna was placed 3m in front of the EUT and Support system, and dwell time of the radiated interference was controlled by an automated, computer-controlled system. The signal source was stepped through the applicable frequency range at a rate no faster than 1% of the fundamental. The signal was amplitude modulated 80% over the frequency range 80 MHz to 1GHz and 1.4GHz to 6GHz at a level of 3 V/m. The dwell time was set at 1.5 s. Field presence was monitored during testing via a field probe placed in close proximity to the EUT. Throughout testing, the EUT was closely monitored for signs of susceptibility. The test was performed with the antennae oriented in both a horizontal and vertical polarization.

All the scanning conditions are as follows :

Condition of Test	Remarks
1. Test Fielded Strength	3 V/m (Severity Level 2)
2. Radiated Signal	80% amplitude modulated with a 1kHz sine wave
3. Scanning Frequency	80 - 1000 MHz, 1.4GHz-6GHz
4. Sweeping time of radiated	0.0015 decade/s
5. Dwell Time	1.5 Sec.

## 10.5. Test Results

10.5.1. Test Results: **PASS**

10.5.2. Test data on the following pages.





# 11. MAGNETIC FIELD IMMUNITY TEST

## 11.1. Configuration of Test System

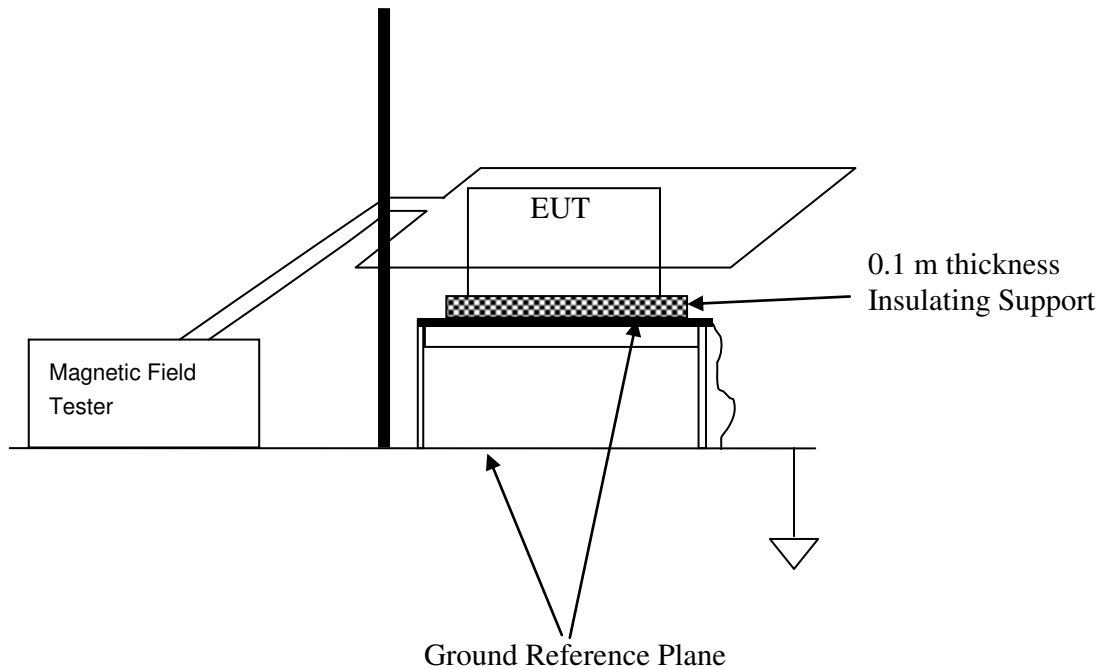

## 11.2. Test Standard

EN IEC 61000-6-1:2019 (EN 61000-4-8)  
(Severity Level 2 at 3A/m)

## 11.3. Severity Levels and Performance Criterion

### 11.3.1. Severity level

Level	Magnetic Field Strength A/m
1.	1
2.	3
3.	10
4.	30
5.	100
X.	Special

### 11.3.2. Performance criterion : A

#### 11.4. Test Procedure

The EUT was subjected to the test magnetic field by using the induction coil of standard dimensions (1m\*1m) and shown in Section 11.1. The induction coil was then rotated by 90° in order to expose the EUT to the test field with different orientations.

#### 11.5. Test Results

11.5.1. Test Results: **PASS**

11.5.2. Test data on the following pages.



# **APPENDIX I**

EUT:	Sealed Lead Acid Battery	M/N:	12V120AH
Mode:	Discharging	Polarization:	Vertical
Tested by:	Rosa	Power:	DC 12V by Battery
Temperature: / Humidity	21.4°C / 51.0%	Test date:	2022-12-02

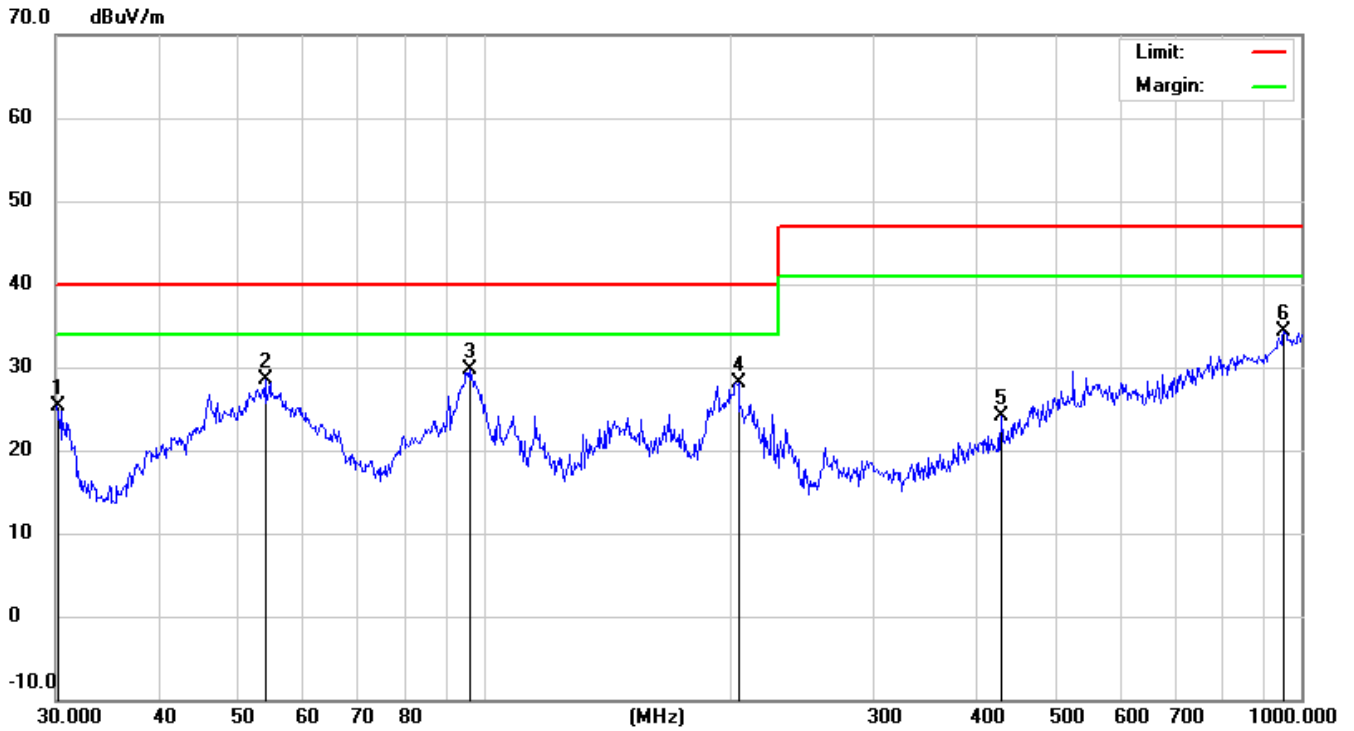

No.	Mk.	Freq. MHz	Reading Level dBuV	Correct Factor dB	Measure- ment dBuV/m	Limit dBuV/m	Over dB	Detector	Antenna Height cm	Table Degree degree	Comment
1		30.1054	4.53	20.83	25.36	40.00	-14.64	QP			
2		54.0711	20.28	8.30	28.58	40.00	-11.42	QP			
3	*	96.0986	17.53	12.16	29.69	40.00	-10.31	QP			
4		204.9551	13.13	15.06	28.19	40.00	-11.81	QP			
5		429.5228	5.22	18.96	24.18	47.00	-22.82	QP			
6		952.0937	4.86	29.52	34.38	47.00	-12.62	QP			

\*:Maximum data    x:Over limit    !:over margin

EUT:	Sealed Lead Acid Battery	M/N:	12V120AH
Mode:	Discharging	Polarization:	Horizontal
Tested by:	Rosa	Power:	DC 12V by Battery
Temperature: / Humidity	21.4°C / 51.0%	Test date:	2022-12-02

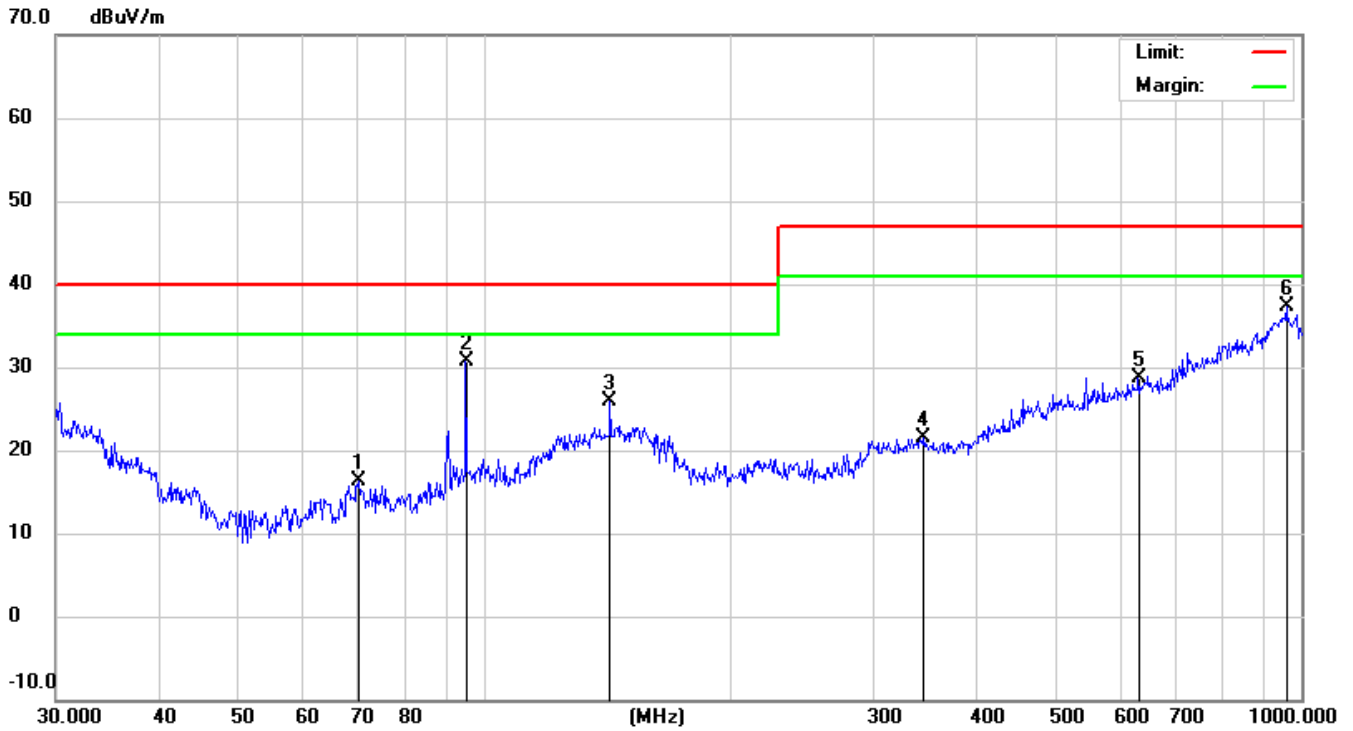

No.	Mk.	Freq.	Reading Level	Correct Factor	Measurement	Limit	Over	Antenna Height	Table Degree	
		MHz	dBuV	dB	dBuV/m	dBuV/m	dB	cm	degree	Comment
1		70.3365	7.06	9.33	16.39	40.00	-23.61	QP		
2	*	95.0930	18.86	11.78	30.64	40.00	-9.36	QP		
3		142.8243	9.05	16.77	25.82	40.00	-14.18	QP		
4		345.5952	5.06	16.37	21.43	47.00	-25.57	QP		
5		631.6884	4.52	24.21	28.73	47.00	-18.27	QP		
6		958.7943	7.77	29.59	37.36	47.00	-9.64	QP		

\*:Maximum data    x:Over limit    !:over margin

EUT:	Sealed Lead Acid Battery	M/N:	12V120AH
Mode:	Charging	Polarization:	Vertical
Tested by:	Rosa	Power:	DC 15V by DC Source
Temperature: / Humidity	21.4°C / 51.0%	Test date:	2022-12-02

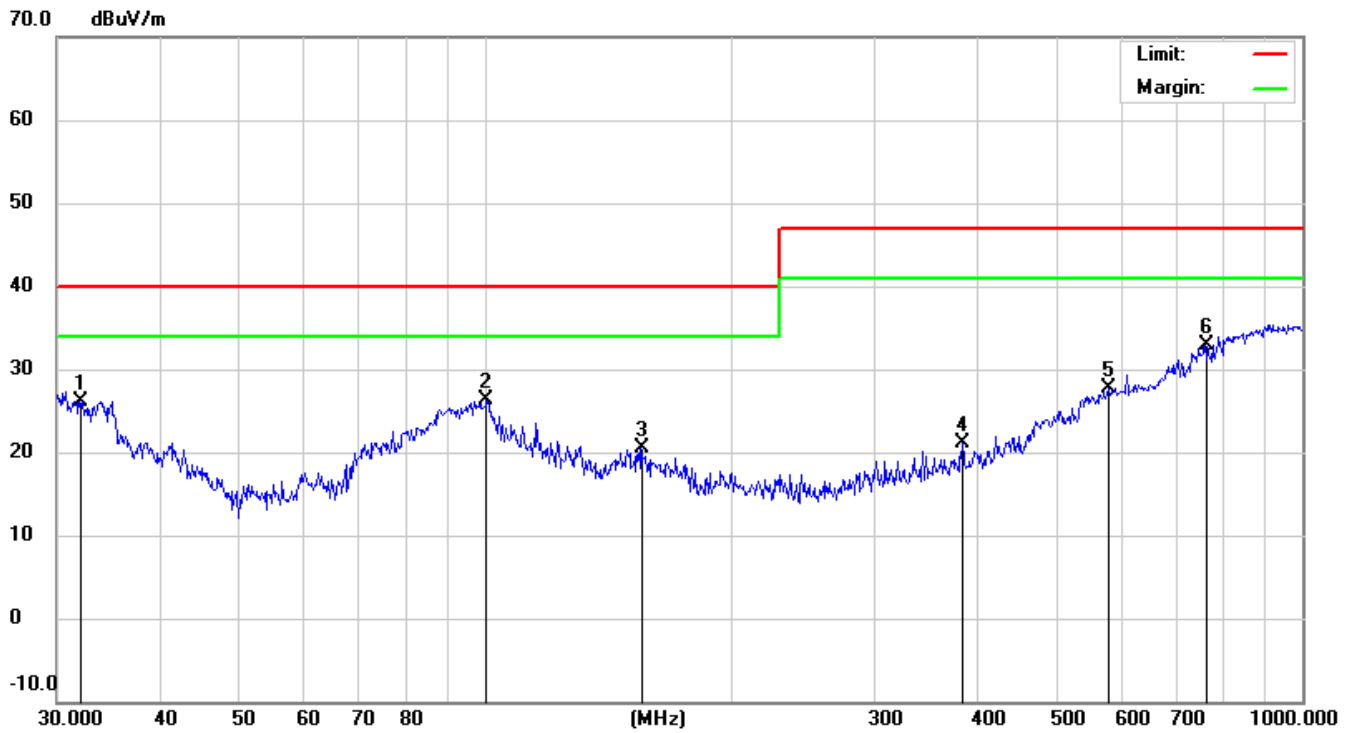

No.	Mk.	Freq.	Reading Level	Correct Factor	Measurement	Limit	Over	Antenna Height	Table Degree	
		MHz	dBuV	dB	dBuV/m	dBuV/m	dB	cm	degree	Comment
1		31.9546	6.57	19.57	26.14	40.00	-13.86			QP
2	*	100.5806	12.55	13.66	26.21	40.00	-13.79			QP
3		155.3644	3.00	17.49	20.49	40.00	-19.51			QP
4		383.9318	4.03	17.09	21.12	47.00	-25.88			QP
5		578.6699	4.20	23.57	27.77	47.00	-19.23			QP
6		760.7036	6.06	26.80	32.86	47.00	-14.14			QP

\*:Maximum data    x:Over limit    !:over margin

EUT:	Sealed Lead Acid Battery	M/N:	12V120AH
Mode:	Charging	Polarization:	Horizontal
Tested by:	Rosa	Power:	DC 15V by DC Source
Temperature: / Humidity	21.4°C/ 51.0%	Test date:	2022-12-02

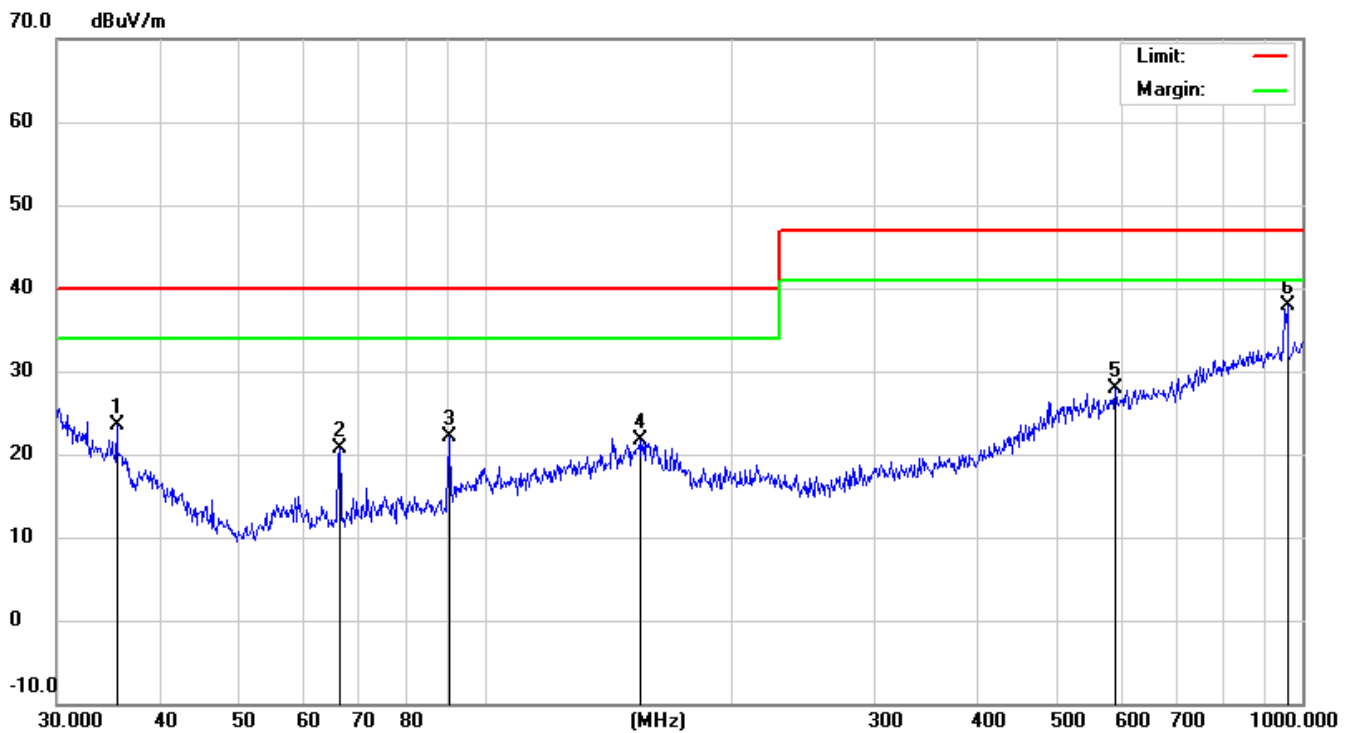

No.	Mk.	Freq. MHz	Reading Level dBuV	Correct Factor dB	Measure- ment dBuV/m	Limit dBuV/m	Over dB	Detector	Antenna Height cm	Table Degree	Comment
1		35.4992	6.34	17.13	23.47	40.00	-16.53	QP			
2		66.4989	11.66	9.05	20.71	40.00	-19.29	QP			
3		90.5374	12.09	10.10	22.19	40.00	-17.81	QP			
4		154.8204	4.10	17.51	21.61	40.00	-18.39	QP			
5		590.9737	4.28	23.70	27.98	47.00	-19.02	QP			
6	*	958.7943	8.25	29.59	37.84	47.00	-9.16	QP			

\*:Maximum data    x:Over limit    !:over margin

**APPENDIX II**  
(Photos of the EUT)



**Figure 3**  
General Appearance of the EUT

